

TECHNICAL DATA SHEET



KTS350-X

Region

North America

Full range

1000m/ 3280ft

Field of view

360°

All conditions

In poor visibility

NO MAINTENANCE

Each ClearWay radar dish rotates at 4Hz inside the enclosure, meaning millions of rotations throughout its 10-year lifecycle. All radars incorporate ultra-reliable and zero maintenance direct-drive motor units, giving service-free operation for each device whilst installed at the roadside.

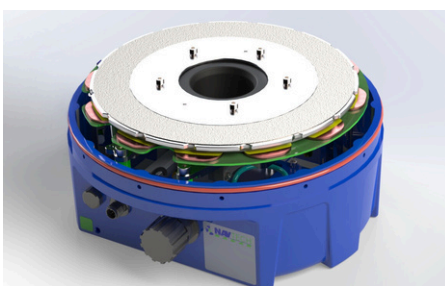

NEMA TS2 Section 2
FCC approved
Patented

ClearWay™

360° radar-based automatic incident detection

ClearWay is Navtech Radar's 360° radar-based incident detection and traffic data system that operates in all weather and lighting conditions, including in complete darkness. Navtech's reliable 360° scanning radars are coupled with intelligent tracking algorithms and sophisticated decision-making software to give you full situational awareness on your road when you need it the most. ClearWay has been deployed across the world in some of the most challenging conditions and is proven to make roads safer and improve journey times.

Choose ClearWay On-Prem with your existing fibre network or choose ClearWay Cloud with a 4G connection* to your dedicated cloud hosted interface.

TECHNICAL SPECIFICATIONS

DIMENSIONS

Measurements	H545mm x D420mm - 21.5in x 16.5in
Weight	11kg / 24.2lbs

RADAR CHARACTERISTICS

	Max range
Radius	500m / 1640ft
Full range	1000m / 3280ft
Range resolution	0.175m / 0.57in
Measurement rate	400 per rotation
Field of view	360°
	Beam shape
Horizontal	1.8°
Vertical	3.6°
Azimuth sampling	0.9°

CONNECTION

	Connectors
Power	M12 5 wire
Ethernet	IP67 connector - RJ45 CAT5e - 1 Gbps ethernet
Earth	M5 thread
Pressurisation valve	Yes
	Network
Speed	100/1000Mbps (configurable)
Bandwidth	<0.5Mbps per radar in normal operation ~38Mbps viewing full disc raw data (for commissioning only)
	Direct power variant
Voltage input	24V DC
Tolerance	21.6V to 26.4V
Consumption	30W (45W with heater activated)

ENVIRONMENT

Operating Temperature	-34°C to +74°C / -29.2°F to +165.2°F
Enclosure	UL50/50E
Weather	Fully functional in wind, rain, snow, fog, ice, humidity 0-100% condensing
Visibility	Full performance through fog and smoke
IP rating	IP67
Saline	BS EN 60068-2-52:1996 Test Kb Severity 3

ELECTRICAL AND RADIO

Radar frequency	34-35 GHz
Compliance	KC, FCC, ISED, NEMA TS2 Section 2

SOFTWARE

Protocols	TCP/IP, UDP, IPv4, HTTP, HTTPS, TLS1.2, SSH
Interface	Vertex via web browser
Authenticated access	Yes
Signed software	Yes - SHA512

SECURITY

Encryption library	Botan
Authentication	Yes (password change or reset through admin account)
Account management	Password update only (3 inbuilt accounts)
Firewall / Access Control	Yes
SSH	Yes
Secure mode	Yes (closes port 80, only allows SSH with secure key, no UDP multicast)

ACCREDITATION AND COMPLIANCE

NEMA TS2	TS-2-2021 V03.08, Section 2
FCC	Yes

PATENTS

Patent

US Patent No. 10 522 893

ADDITIONAL NOTES

Notes

*EPU required, datasheet available

DIMENSIONS

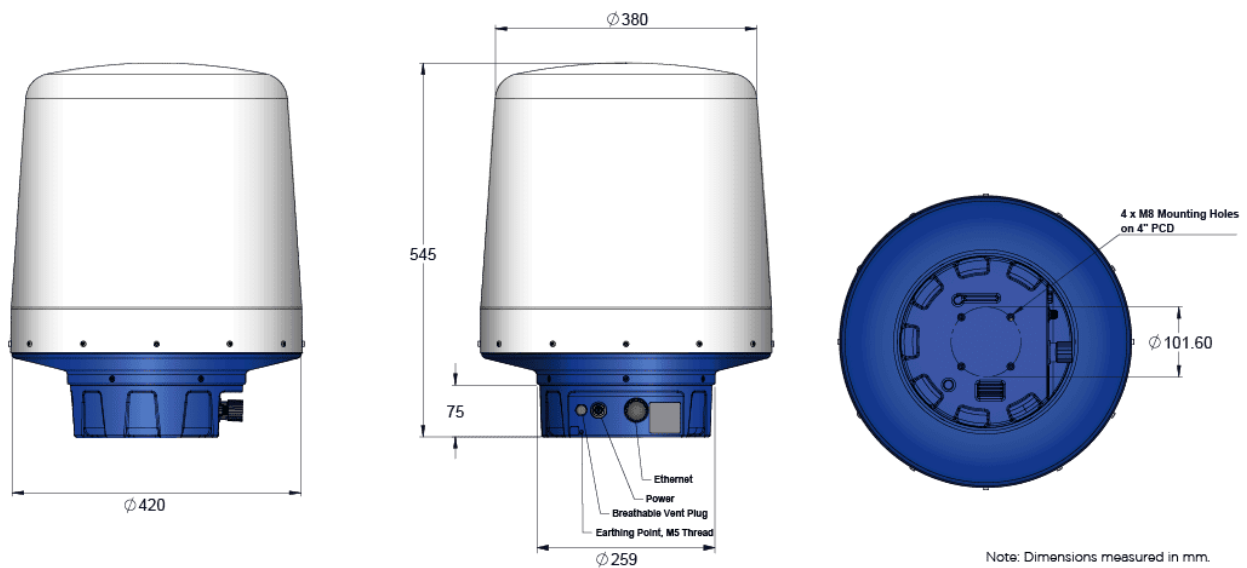

Specifications are subject to change without notice.
All images used are for illustrative purposes only.
Due to customer use beyond our control, Navtech Radar cannot assess product relevance for specific applications. Customers are responsible for testing products and reviewing regulations to ensure safe operation.



Navtech complies with the following ISO standards

ISO 9001:2015 Quality
ISO 27001 Information Security
ISO 20000 IT Service Management
ISO 45001 Health and Safety
ISO 14001 Environmental

Navtech Radar

+44 (0) 1235 832 419

www.navtechradar.com



Safety is everything.

ITS-PM-0002 V2.1